



TAI-SAW TECHNOLOGY CO., LTD.

No. 3, Industrial 2nd Rd., Ping-Chen Industrial District,
Taoyuan, 324, Taiwan, R.O.C.

TEL: 886-3-4690038 FAX: 886-3-4697532

E-mail: tstsales@mail.taisaw.com Web: www.taisaw.com

Approval Sheet For Product Specification

Issued Date:3/5/2008 (REV. NO: 1.0)

Product Name: HC49SMD 12MHz Crystal Unit

TST Parts No.: TZ1390A

Customer Parts No. : _____

Company: _____
Division: _____
Approved by: _____
Date: _____

Checked by: _____ Quinton Lo

Approval by: _____ Robert Chang

Date: _____ 3/5/2008



TAI-SAW TECHNOLOGY CO., LTD.

No. 3, Industrial 2nd Rd., Ping-Chen Industrial District,
Taoyuan, 324, Taiwan, R.O.C.

TEL: 886-3-4690038 FAX: 886-3-4697532

E-mail: tstsales@mail.taisaw.com Web: www.taisaw.com

HC49SMD 12MHz Crystal Unit

MODEL NO.: TZ1390A

REV. NO.: 1.0

Features:

- Good Frequency Stability

RoHS Compliant
Lead free
Lead-free soldering

Description and Applications:

HC49SMD crystal unit for use in wireless telecommunications devices

Electrical Specifications:

TZ1390A	Specification
Nominal Frequency	12MHz
Mode of Oscillation	Fundamental
Storage Temperature Range	-40°C~+85°C
Operating Temperature Range	-20°C~+70°C
Frequency Stability over Operating Temperature Range	+/-30 ppm (referred to the value at 25°C)
Frequency Make Tolerance (FL)	+/-30 ppm @ 25°C +/- 3°C
Equivalent Series Resistance (ESR)	80 Ω max.
Nominal Drive Level	100 uW
Shunt Capacitance (Co)	7.0 pF MAX
Load Capacitance (CL)	18 pF
Aging	+/-3.0 ppm/year
Insulation Resistance	500 MΩ min./DC 100V
Marking	Laser marking

Mechanical Dimensions (mm):

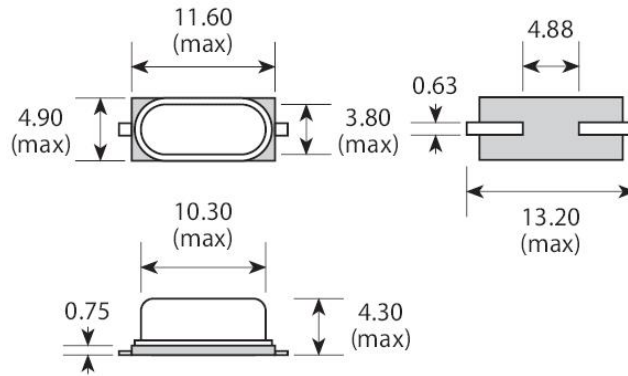

Marking:

Line 1: Frequency

Line 2: TST Logo + Product code + Date Code + Traceability Code (X)

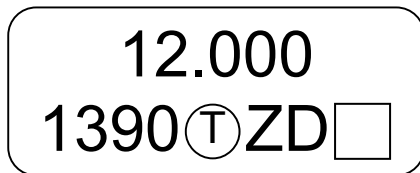

Product Code Table

Year	2001	2002	2003	2004
	2005	2006	2007	2008
Product Code	Z	z	z̄	z̄

Date Code Table

WK01	WK02	WK03	WK04	WK05	WK06	WK07	WK08	WK09	WK10	WK11	WK12	WK13
A	B	C	D	E	F	G	H	I	J	K	L	M
WK14	WK15	WK16	WK17	WK18	WK19	WK20	WK21	WK22	WK23	WK24	WK25	WK26
N	O	P	Q	R	S	T	U	V	W	X	Y	Z
WK27	WK28	WK29	WK30	WK31	WK32	WK33	WK34	WK35	WK36	WK37	WK38	WK39
a	b	c	d	e	f	g	h	i	j	k	l	m
WK40	WK41	WK42	WK43	WK44	WK45	WK46	WK47	WK48	WK49	WK50	WK51	WK52
n	o	p	q	r	s	t	u	v	w	x	y	z

PACKING:

1. REEL DIMENSION (Unit: mm)

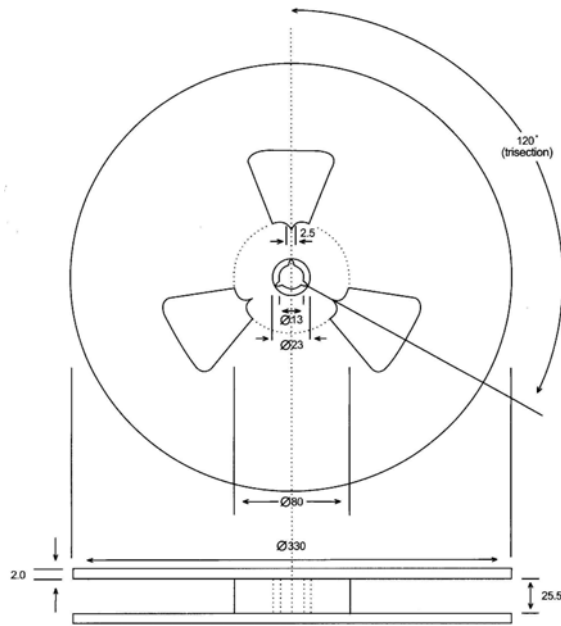

2. TAPE DIMENSION (Unit: mm)

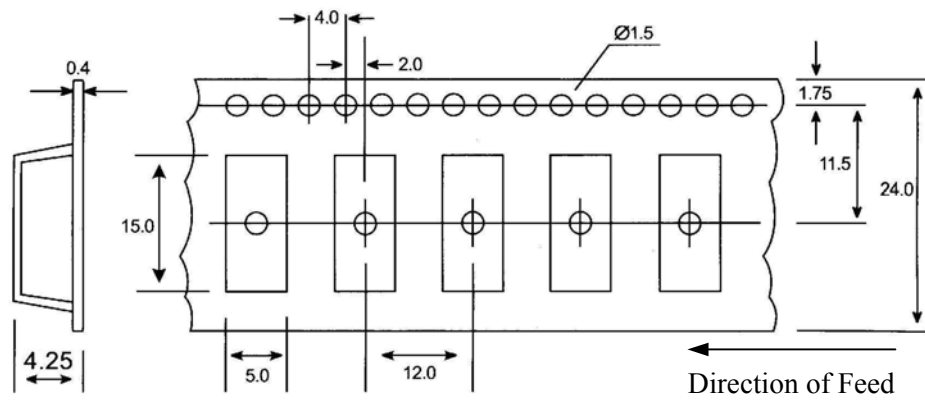

3. PACKING DIRECTION

The letter "1" in the marking should be closed to the hole of tape.